



### Main

Range of product	Zelio Logic
Product or component type	Compact smart relay

### Complementary

Local display	With
Number of control scheme lines	0...240 with ladder programming 0...500 with FBD programming
Cycle time	6...90 Ms
Backup time	10 years at 25 °C
Clock drift	12 min/year at 0...55 °C 6 s/month at 25 °C
Checks	Program memory on each power up
[Us] rated supply voltage	100...240 V AC
Supply voltage limits	85...264 V
Supply frequency	50/60 Hz
Maximum supply current	100 MA at 100 V (without extension) 50 MA at 240 V (without extension)
Power consumption in VA	11 VA without extension
Isolation voltage	1780 V
Protection type	Against inversion of terminals (control instructions not executed)
Discrete input number	12
Discrete input voltage	100...240 V AC
Discrete input current	0.6 MA
Discrete input frequency	57...63 Hz 47...53 Hz
Voltage state 1 guaranteed	$\geq 79$ V for discrete input
Voltage state 0 guaranteed	$\leq 40$ V for discrete input
Current state 1 guaranteed	$\geq 0.17$ mA (discrete input)
Current state 0 guaranteed	$\leq 0.5$ mA (discrete input)
Input impedance	350 kOhm for discrete input
Number of outputs	8 relay
Output voltage limits	5...30 V DC (relay output) 24...250 V AC
Contacts type and composition	NO for relay output
Output thermal current	8 A for all 8 outputs for relay output

Electrical durability	AC-12: 500000 cycles at 230 V, 1.5 A for relay output conforming-to EN/IEC 60947-5-1 AC-15: 500000 cycles at 230 V, 0.9 A for relay output conforming-to EN/IEC 60947-5-1 DC-12: 500000 cycles at 24 V, 1.5 A for relay output conforming-to EN/IEC 60947-5-1 DC-13: 500000 cycles at 24 V, 0.6 A for relay output conforming-to EN/IEC 60947-5-1
Switching capacity in mA	>= 10 mA at 12 V (relay output)
Operating rate in Hz	0.1 Hz (at Ie) for relay output 10 Hz (no load) for relay output
Mechanical durability	10000000 Cycles for relay output
[Uimp] rated impulse withstand voltage	4 KV conforming to EN/IEC 60947-1 and EN/IEC 60664-1
Clock	With
Response time	50 ms with ladder programming (from state 0 to state 1) for discrete input 50 ms with ladder programming (from state 1 to state 0) for discrete input 50...255 ms with FBD programming (from state 0 to state 1) for discrete input 50...255 ms with FBD programming (from state 1 to state 0) for discrete input 10 ms (from state 0 to state 1) for relay output 5 ms (from state 1 to state 0) for relay output
Connections - terminals	Screw terminals, 1 x 0.2...1 x 2.5 mm <sup>2</sup> (AWG 25...AWG 14) semi-solid Screw terminals, 1 x 0.2...1 x 2.5 mm <sup>2</sup> (AWG 25...AWG 14) solid Screw terminals, 1 x 0.25...1 x 2.5 mm <sup>2</sup> (AWG 24...AWG 14) flexible with cable end Screw terminals, 2 x 0.2...2 x 1.5 mm <sup>2</sup> (AWG 24...AWG 16) solid Screw terminals, 2 x 0.25...2 x 0.75 mm <sup>2</sup> (AWG 24...AWG 18) flexible with cable end
Tightening torque	0.5 N.M
Overvoltage category	III conforming to EN/IEC 60664-1
Net weight	0.38 Kg

## Environment

Immunity to microbreaks	1 Ms
Product certifications	C-Tick CSA GL GOST UL
Standards	EN/IEC 61000-4-6 level 3 EN/IEC 61000-4-11 EN/IEC 60068-2-27 Ea EN/IEC 61000-4-5 EN/IEC 60068-2-6 Fc EN/IEC 61000-4-12 EN/IEC 61000-4-2 level 3 EN/IEC 61000-4-3 EN/IEC 61000-4-4 level 3
IP degree of protection	IP20 (terminal block) conforming to IEC 60529 IP40 (front panel) conforming to IEC 60529
Environmental characteristic	EMC directive conforming to EN/IEC 61000-6-2 EMC directive conforming to EN/IEC 61000-6-3 EMC directive conforming to EN/IEC 61000-6-4 EMC directive conforming to EN/IEC 61131-2 zone B Low voltage directive conforming to EN/IEC 61131-2
Disturbance radiated/conducted	Class B conforming to EN 55022-11 group 1
Pollution degree	2 conforming to EN/IEC 61131-2
Ambient air temperature for operation	-20...40 °C in non-ventilated enclosure conforming-to IEC 60068-2-1 and IEC 60068-2-2 -20...55 °C conforming to IEC 60068-2-1 and IEC 60068-2-2
Ambient air temperature for storage	-40...70 °C
Operating altitude	2000 m
Maximum altitude transport	3048 M
Relative humidity	95 % without condensation or dripping water

## Packing Units

Unit Type of Package 1	PCE
Number of Units in Package 1	1
Package 1 Weight	371 G
Package 1 Height	6.8 Cm
Package 1 width	10 Cm
Package 1 Length	13.5 Cm
Unit Type of Package 2	S03
Number of Units in Package 2	20
Package 2 Weight	7.828 Kg
Package 2 Height	30 Cm
Package 2 width	30 Cm
Package 2 Length	40 Cm

## Offer Sustainability

Sustainable offer status	Green Premium product
EU RoHS Directive	Pro-active compliance (Product out of EU RoHS legal scope) <a href="#">EU RoHS Declaration</a>
Mercury free	Yes
RoHS exemption information	<a href="#">Yes</a>
China RoHS Regulation	<a href="#">China RoHS Declaration</a>
Environmental Disclosure	<a href="#">Product Environmental Profile</a>
Circularity Profile	<a href="#">End Of Life Information</a>
WEEE	The product must be disposed on European Union markets following specific waste collection and never end up in rubbish bins
PVC free	Yes

## Contractual warranty

Warranty	18 months
----------	-----------

Compact and Modular Smart Relays

Mounting on 35 mm/1.38 in. DIN Rail

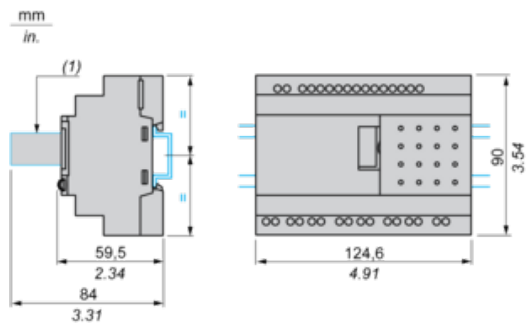

(1) With SR2USB01 or SR2BTC01

Screw Fixing (Retractable Lugs)

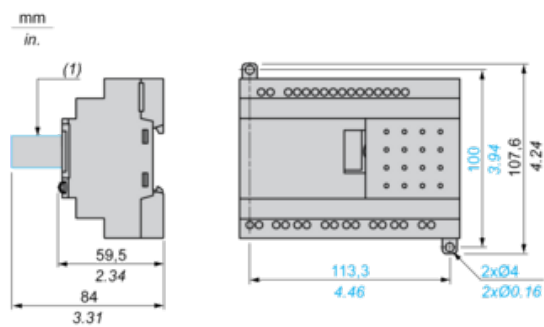

(1) With SR2USB01 or SR2BTC01

Position of Display

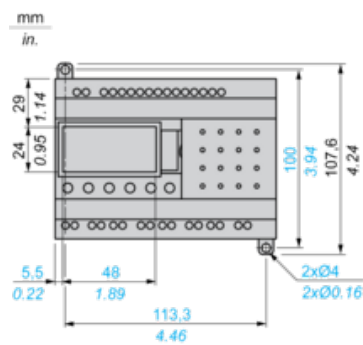

Connection of Smart Relays on AC Supply

SR••••1B, SR••••1FU

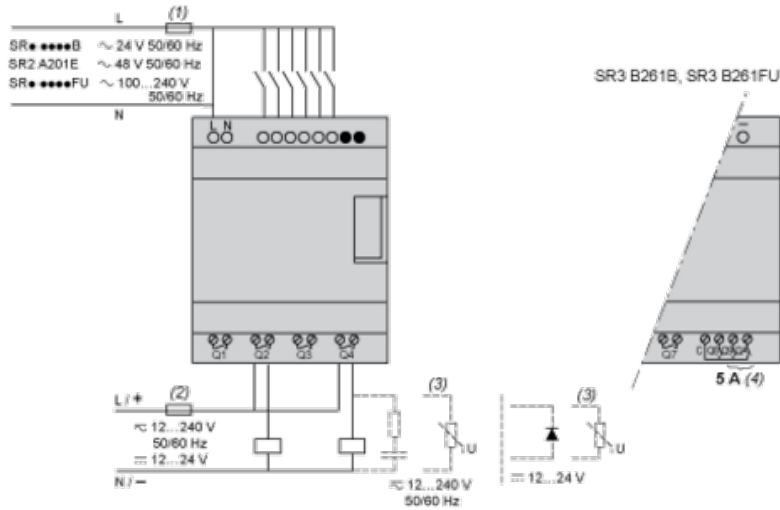

- (1) 1 A quick-blow fuse or circuit-breaker.
- (2) Fuse or circuit-breaker.
- (3) Inductive load.
- (4) Q9 and QA: 5 A (max. current in terminal C: 10 A).

With Discrete I/O Extension Module

SR3B•••B + SR3XT•••B, SR3B•••FU + SR3XT•••FU

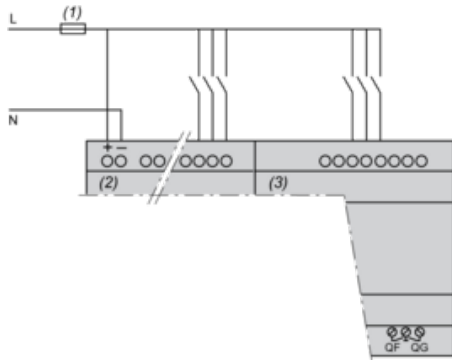

- (1) 1 A quick-blow fuse or circuit-breaker.
- NOTE: QF and QG: 5 A for SR3XT141••

Compact and Modular Smart Relays

Electrical Durability of Relay Outputs

(in millions of operating cycles, conforming to IEC/EN 60947-5-1)

AC-12 (1)

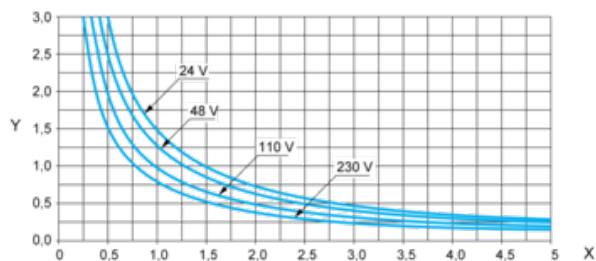

X: Current (A)

Y: Millions of operating cycles

(1) AC-12: switching resistive loads and opto-coupler isolated solid-state loads,  $\cos \geq 0.9$ .

AC-14 (1)

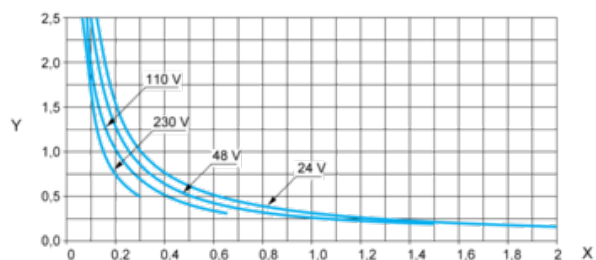

X: Current (A)

Y: Millions of operating cycles

(1) AC-14: switching small electromagnetic loads  $\leq 72$  VA, make:  $\cos = 0.3$ , break:  $\cos = 0.3$ .

AC-15 (1)

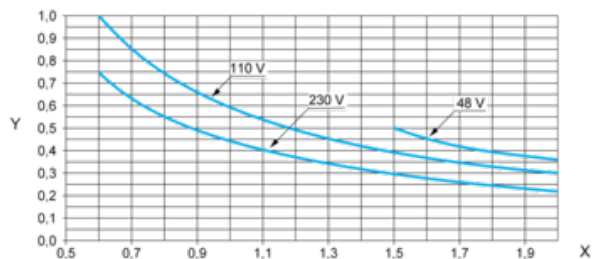

X: Current (A)

Y: Millions of operating cycles

(1) AC-15: switching electromagnetic loads  $\geq 72$  VA, make:  $\cos = 0.7$ , break:  $\cos = 0.4$ .

Product Life Status : **Commercialised**