

METALLIC JOBSITE BOX

EGA Master chests are specially designed for use in even the most harsh conditions, such as those found in construction or any fields that require the use of large tools. **Four sizes are available, to match the requirements of the user.**

The long lasting powder coated finish is very resistant and ready for use in demanding conditions.

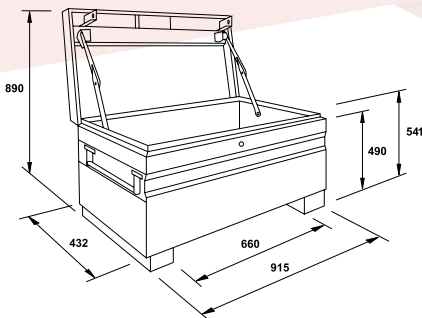

1. Central locking system (2keys).

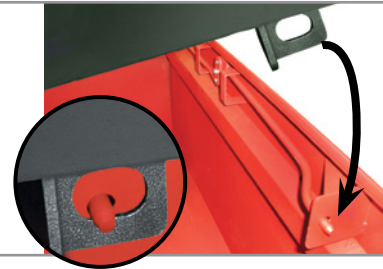

2. Made of high quality steel.

3. Side handles.

4. It can be easily carried by pallet thanks to the special leg design.

5. Lateral reinforcement.

6. EGA Master chests are specially designed so that the smaller chest can be fitted inside the larger chest. Code 51048 inside code 51047 • Code 51047 inside 51046. This feature will enables reduced transportation costs and more efficient use of storage space.

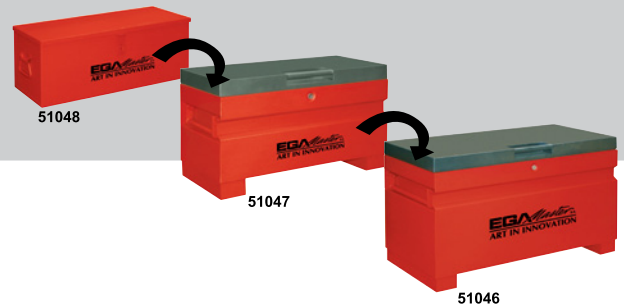

COD	LxWxH	Overall thickness	Base thickness	Kg. MAX	Kg.
51047	915x432x541	1,5mm	2,5mm	200	40