

WIRE TWIST PLIER

The wide EGA Master automotive tools range has been developed to cover the vast majority of the needs for the professional motor vehicle repair and tuning up.

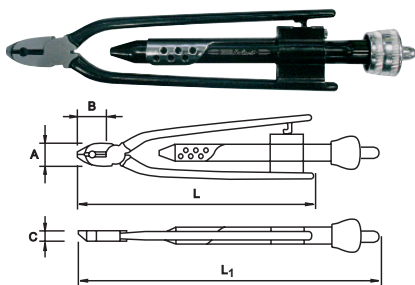

Tensile strength - break: • 75kg/mm² up to 1.5mm • 120Kg/mm²: up to - 1mm • 200Kg/mm²: up to 0,5mm wire



COD	L	A	B	C	D	gr	Box	Case
62624	6"	215	17	23	10	250	6	1
62625	9"	270	21	29	12	380	6	1

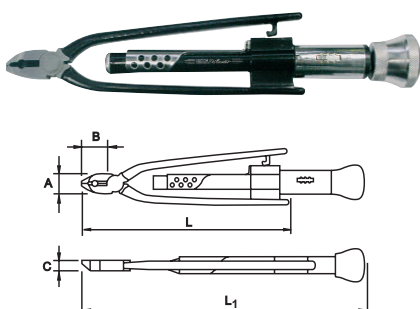

COD	L	A	B	C	D	gr	Box	Case
62627	6"	235	17	23	10	250	6	1
62628	9"	285	21	29	12	380	6	1

Reversible model (provides right and left twist capacity).

WIRE TWIST PLIER

TECHNICAL SPECIFICATIONS

MATERIAL	Cr-V	
FINISHING	Head	Polished
	Body	Black lacquered
GENERAL HARDNESS	40 – 44 HRc.	
HARDNESS OF THE CUTTING EDGE	50 – 55 HRc.	
HARDNESS OF THE PIN	40 – 50 HRc.	