

# ADJUSTABLE WRENCHES

TITACROM®



EGA Master manufactures the widest range of adjustable wrenches in the world, available in multiple sizes, versions and with unique innovations. The rugged design makes an Adjustable Wrench ideal for heavy duty applications with its high resistance when tightening.



Both right and left turn versions available. Maximum opening and minimum jaw thickness for the very best versatility.

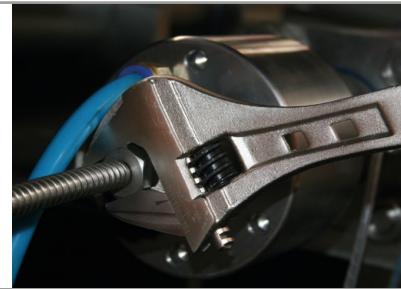

Available in a Titacrom or phosphated finish.

Available with or without a Bi-material Anti-slip Comfort Grip Handle for maximum comfort and user appeal.

Also available with 1000V insulation.

TITACROM

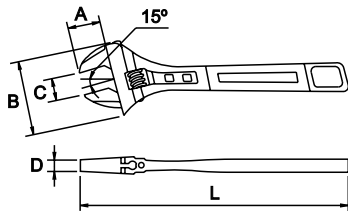

COD	←L→	* lb.in	←A→	←B→	←C→	←D→	gr.		
61109	4"-100mm	600	13	34	13	5,5	70	12	
61110	6"-150mm	1450	20	47	19	6,5	150		10
61111	8"-200mm	2700	25	55	24	7,0	280	10	
61112	10"-250mm	4500	30	70	29	8,5	500		8
61113	12"-300mm	7650	35	85	33	10	850	8	
61114	15"-375mm	15000	44	105	45	13	1200		
61115	18"-450mm	20000	50	120	55	14	2000	1	1
61116	24"-600mm	25000	60		60	15	3100		
62980	30"-750mm	27500	75	180	85	17	5600		

GGG-W-631B. ANSI B-107.8M

\* lb. in: minimum torque moment according to the ANSI B 107.8 standard

## TECHNICAL SPECIFICATIONS

MATERIAL	Special Steel
HARDNESS	40-50 HRc.
FINISHING	Titacrom®

UNLIMITED GUARANTEE

**TITACROM COMFORT**

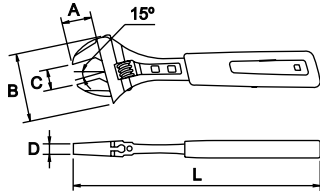

COD	←L→	* lb.in	←A→	←B→	←C→	←D→	gr.		
61906	6"-150mm	1450	20	47	19	6,5	180	6	6
61907	8"-200mm	2700	25	55	24	7,0	330		
61908	10"-250mm	4500	30	70	29	8,5	600		
61909	12"-300mm	7650	35	85	33	10	900		



61370	15"-375mm	15000	44	105	45	13	1250	1	1
61371	18"-450mm	20000	50	120	55	14	2050		
61372	24"-600mm	25000	60	120	62	15	3150		

GGG-W-631B. ANSI B-107.8M

\* lb. in: minimum torque moment according to the ANSI B 107.8 standard

**TECHNICAL SPECIFICATIONS**

MATERIAL	Wrench: Special Steel Handle: PVC
HARDNESS	40-50 HRc.
FINISHING	Wrench: Titacrom® Handle: Black

**TITACROM 1000V**

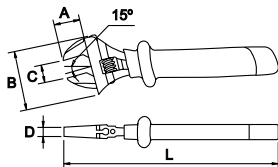

COD	←L→	* lb.in	←A→	←B→	←C→	←D→	gr.		
76550	6"-150mm	1450	20	47	19	6,5	200	4	
76551	8"-200mm	2700	25	55	24	7,0	360		
76552	10"-250mm	4500	30	70	29	8,5	600		
76553	12"-300mm	7650	35	85	33,5	10	950		

GGG-W-631B. ANSI B-107.8M

\* lb. in: minimum torque moment according to the ANSI B 107.8 standard

The insulated adjustable wrenches 1000V can not be homologated as the wheel nut can not be insulated. The safety of the user can not be guaranteed, even though the insulated material fulfils the requirements of the norm EN-60900 regarding the electrical resis-

**TECHNICAL SPECIFICATIONS**

MATERIAL	Wrench: Special Steel Handle: PVC
HARDNESS	40-50 HRc.
FINISHING	Wrench: Titacrom® Handle: Orange RAL 2011 and Black

**PHOSPHATED**

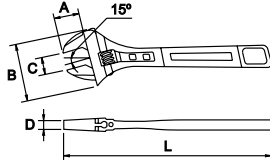

COD	←L→	* lb.in	←A→	←B→	←C→	←D→	gr.	gr.	gr.
61136	4"-100mm	600	13	34	13	5,5	70	12	
61117	6"-150mm	1450	20	47	19	6,5	160		10
61118	8"-200mm	2700	25	55	24	7,0	310		10
61119	10"-250mm	4500	30	70	29	8,5	550		8
61120	12"-300mm	7650	35	85	33	10	850		8
61121	15"-375mm	15000	44	105	45	13	1200		
61122	18"-450mm	20000	50	120	55	14	2000	1	1
61123	24"-600mm	25000	60	120	62	15	3100		

GGG-W-631B. ANSI B-107.8M

\* lb. in: minimum torque moment according to the ANSI B 107.8 standard

**TECHNICAL SPECIFICATIONS**

MATERIAL	Special Steel
HARDNESS	40-50 HRc.
FINISHING	PHOSPHATED

**PHOSPHATED COMFORT**

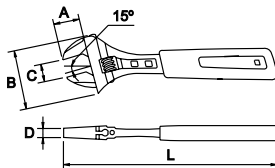

COD	←L→	* lb.in	←A→	←B→	←C→	←D→	gr.	gr.	gr.
61898	6"-150mm	1450	20	47	19	6,5	180		
61910	8"-200mm	2700	25	55	24	7,0	330		
61911	10"-250mm	4500	30	70	29	8,5	600		
61912	12"-300mm	7650	35	85	33	10	900		
61373	15"-375mm	15000	44	105	45	13	1250		
61374	18"-450mm	20000	50	120	55	14	2050	1	1
61375	24"-600mm	25000	60	120	60	15	3150		

GGG-W-631B. ANSI B-107.8M

\* lb. in: minimum torque moment according to the ANSI B 107.8 standard

**TECHNICAL SPECIFICATIONS**

MATERIAL	Wrench: Special Steel Handle: PVC
HARDNESS	40-50 HRc.
FINISHING	Wrench: Phosphated Handle: Black

**PHOSPHATED 1000V**

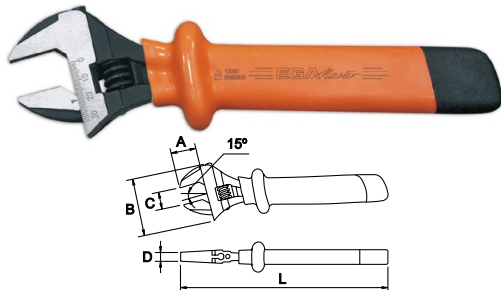

COD	←L→	* lb.in	←A→	←B→	←C→	←D→	gr.	
76554	6"-150mm	1450	20	47	19	6,5	195	4
76555	8"-200mm	2700	25	55	24	7,0	370	
76556	10"-250mm	4500	30	70	29	8,5	650	
76557	12"-300mm	7650	35	85	33	10	1050	

GGG-W-631B. ANSI B-107.8M

\* lb. in: minimum torque moment according to the ANSI B 107.8 standard

The insulated adjustable wrenches 1000V can not be homologated as the wheel nut can not be insulated. The safety of the user can not be guaranteed, even though the insulated material fulfils the requirements of the norm EN-60900 regarding the electrical resistance.

# TECHNICAL SPECIFICATIONS

MATERIAL	Wrench: Special Steel Handle: PVC
HARDNESS	40-50 HRc.
FINISHING	Wrench: Phosphated Handle: Orange RAL 2011 and Black

**SCANDINAVIAN TYPE**



**PHOSPHATED**

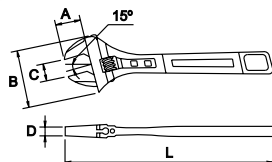

COD	←L→	* lb.in	←A→	←B→	←C→	←D→	gr.	
60550	6"-150mm	1450	20	47	19	6,5	160	10
60552	10"-250mm	4500	30	70	29	8,5	550	
60553	12"-300mm	7650	35	85	33,5	10	850	



60554	15"-375mm	15000	44	105	45	13	1200	1
60555	18"-450mm	20000	50	120	55	14	2000	
60556	24"-600mm	25000	60	120	62	15	3100	

GGG-W-631B. ANSI B-107.8M

\* lb. in: minimum torque moment according to the ANSI B 107.8 standard

# TECHNICAL SPECIFICATIONS

MATERIAL	Special Steel
HARDNESS	40-50 HRc.
FINISHING	PHOSPHATED



**SCANDINAVIAN TYPE**

**LEFT TURN**



**PHOSPHATED COMFORT**

**SCANDINAVIAN - LEFT TURN**

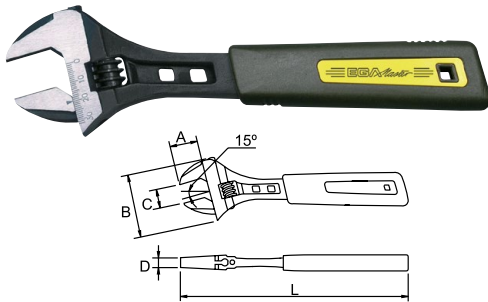

COD	←L→	←A→	←B→	←C→	←D→	gr.		
60548	6"-150mm	20	47	19	6,5	180	6	1
60557	8"-200mm	25	55	24	7,0	335		
60558	10"-250mm	30	70	29	8,5	595		
60559	12"-300mm	35	85	33	10	900		
60560	15"-375mm	44	105	45	13	1200	1	1
60561	18"-450mm	50	120	55	14	2000		
60562	24"-600mm	60		62	15	3150		

**TECHNICAL SPECIFICATIONS**

MATERIAL	Wrench: Special Steel
	Handle: PVC
HARDNESS	40-50 HRc.
FINISHING	Wrench: Phosphated
	Handle: Black

**PHOSPHATED COMFORT 1000V**

**SCANDINAVIAN - LEFT TURN**

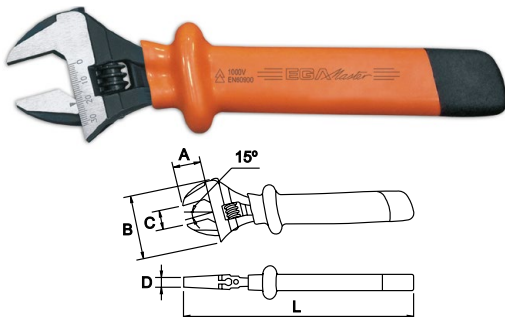

COD	←L→	←A→	←B→	←C→	←D→	gr.		
76570	6"-150mm	20	47	19	6,5	195	4	
76572	10"-250mm	30	70	29	8,5	650		

The insulated adjustable wrenches 1000V can not be homologated as the wheel nut can not be insulated. The safety of the user can not be guaranteed, even though the insulated material fulfils the requirements of the norm EN-60900 regarding the electrical resistance.

**TECHNICAL SPECIFICATIONS**

MATERIAL	Wrench: Special Steel
	Handle: PVC
HARDNESS	40-50 HRc.
FINISHING	Wrench: Phosphated
	Handle: Orange RAL 2011 and Black

UNLIMITED GUARANTEE