



Main

Range of product	Harmony 9001KS
Product or component type	Selector switch
Device short name	9001K
Type of operator	Stay put
Operator profile	Black long handle

Complementary

Bezel material	Chromium plated metal
Mounting diameter	30 Mm
Net weight	0.172 Kg
Shape of signaling unit head	Octagonal
Operator position information	3 positions
Contacts type and composition	Without contact block
Mechanical durability	500000 Cycles
Product compatibility	9001KA1, mounted side 1
Device presentation	Basic element

Environment

Protective treatment	TC
Ambient air temperature for storage	-40...70 °C
Ambient air temperature for operation	-25...70 °C
Overvoltage category	Class II conforming to IEC 61140
IP degree of protection	IP66 conforming to IEC 60529
NEMA degree of protection	NEMA 1 NEMA 12 NEMA 13 NEMA 2 NEMA 3 NEMA 3R NEMA 4
Standards	CSA C22.2 No 14 EN/IEC 60947-5-1 JIS C 4520 EN/IEC 60947-5-4 UL 508 EN/IEC 60947-1 JIS C 852
Product certifications	UL 508 NEMA

Vibration resistance	7 gn (f= 2...500 Hz) conforming to IEC 60068-2-6
Shock resistance	50 gn conforming to IEC 60068-2-27

Packing Units

Unit Type of Package 1	PCE
Number of Units in Package 1	1
Package 1 Weight	122 G
Package 1 Height	9.5 Cm
Package 1 width	5.1 Cm
Package 1 Length	5.8 Cm
Unit Type of Package 2	S01
Number of Units in Package 2	24
Package 2 Weight	3.182 Kg
Package 2 Height	15 Cm
Package 2 width	15 Cm
Package 2 Length	40 Cm

Offer Sustainability

Sustainable offer status	Green Premium product
EU RoHS Directive	Pro-active compliance (Product out of EU RoHS legal scope) EU RoHS Declaration
Mercury free	Yes
RoHS exemption information	Yes
China RoHS Regulation	China RoHS Declaration
Environmental Disclosure	Product Environmental Profile
WEEE	The product must be disposed on European Union markets following specific waste collection and never end up in rubbish bins

Contractual warranty

Warranty	18 months
----------	-----------

Dimensions

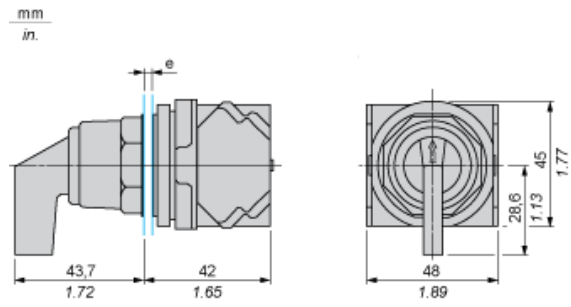

e panel thickness: 1 to 6 mm / 0.04 to 0.24 in.

Contact Block Mounting Position

Top and Rear views

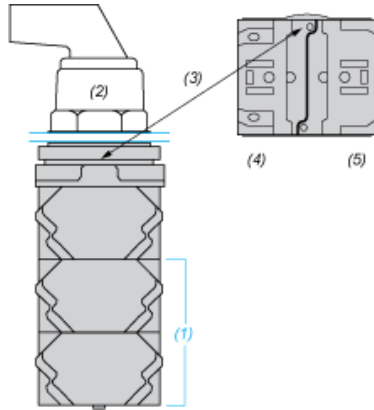

- (1) It is possible to mount up to 3 levels of contacts blocks (maximum of 6 contacts blocks)
- (2) Operator
- (3) Locating notch
- (4) Side 1
- (5) Side 2

Panel Cut-Out

Clearance

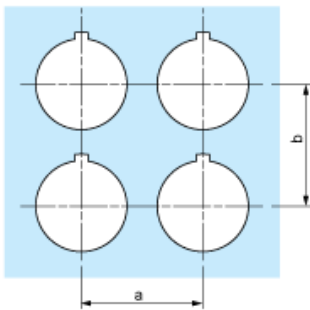

Legend plate	a min.		b min.	
	mm	in.	mm	in.
9001KN2**	57.2	2.25	44.5	1.75
9001KN3**	57.2	2.25	50.8	2.00

Individual Cut-outs Details

2 alternatives

$\frac{\text{mm}}{\text{in.}}$

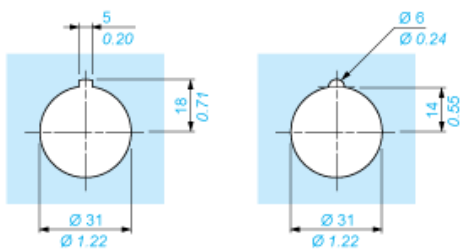

Product Life Status : **Commercialised**